

HERMA 100 Dispensers –
fast and easy hand labelling.



HERMA
Labelling Systems

Labelling made easy – with HERMA 100 dispensers.

By using the HERMA 100 even hand labelling can become an efficient, fast and easy operation.

The HERMA 100 is an electrically driven unit that automatically dispenses labels on demand. The waste backing paper is rewound for safety and ease of disposal. Reliability, ease of use and a small footprint are the main features of the HERMA 100.

The HERMA dispenser is available for reel widths of up to 80 mm or 160 mm.



A backing-paper rewriter ensures smooth operation of the HERMA 100 dispensers.



HERMA 100 Dispenser

Advantages of the HERMA 100 dispensers:

- HERMA dispensers are high-quality products with a one-year warranty. The HERMA 100 dispensers with electric drive are **certified CS** for tested safety and bear the **CE mark**.
- If your dispenser should break down, we will repair it within 24 hours or furnish a free replacement during the warranty period.
- HERMA offers the quality and dependability of an internationally known manufacturer of labelling machines. These advantages are also yours when buying a manual label dispenser.



Reel holder for large rolls

This enables the HERMA 100 to use label reels with diameters of up to 250 mm. The manual dispenser is simply placed upon the base plate of the reel holder and fixed by means of pins.



The new, powerful, expandable HERMA 400 module family.



Proven flexibility. Left and right-hand versions available. Designed for upright, horizontal or suspended operation. Extensive range of accessory modules for practically any labelling task: integrates perfectly into the customer's product line.

HERMA 400 – accessory modules

Dispensing systems · Printing units
Scanning systems · Built-on supports

Outstanding performance all along the line.

HERMA Compact Line – heavy-duty machines for top, bottom or wrap-around labelling with the adaptability of a chameleon. Based on an intelligent, building-block principle with optimized standard modules and top-quality serial control. The modular concept permits made-to-measure solutions to be offered at a price otherwise only matched by „off-the-peg“ products. Thanks to their extremely compact dimensions, the machines also fit without difficulty into a confined working environment.

* HERMA COMPACT LINE

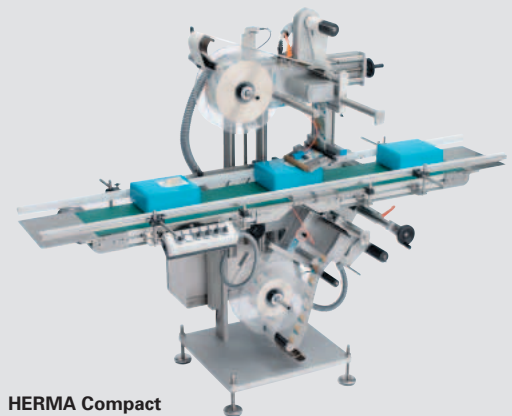

HERMA Compact Line 652 C

Heavy-duty labelling machines

HERMA 362 M: The economical solution for two-side or wrap-around labelling. A rugged mechanical design and powerful, state-of-the-art technology combined with unprecedented operator friendliness. Extremely reliable functioning, very short set-up times, low format costs –

the basis for cost-effective operation with a wide range of products.

HERMA 040 M/132 M: The economical solution for wrap-around labelling in environments where safety is critical. Specially developed for labelling cylindrical products with one or two labels around the circumference. Short retooling times. The tried-and-tested HERMA 040 M/132 M allow variable printing thanks to the option of integrating printing units. Easy to operate and designed with a large number of safety features – also ideal for the pharmaceutical industry.



HERMA 100 – Technical details

Self-adhesive labels

Are practical, useful and particularly convenient. Whether for decoration or conveying important information – they are applied efficiently and accurately with the HERMA 100 label dispenser.

HERMA dispensers are easy to use, extremely robust and very economical.



HERMA quality and know-how is acknowledged all over the world.

Here is why:

- HERMA engineers strive to find perfect solutions for our customer's requirements, down to the smallest detail.
- Even the most unusual tasks can be fulfilled.
- We can adapt our system quickly and economically to suit your technical needs.
- Service is our strength – worldwide.

Even if your labelling requirements are really challenging contact us first. We will provide a solution for your labelling problems.

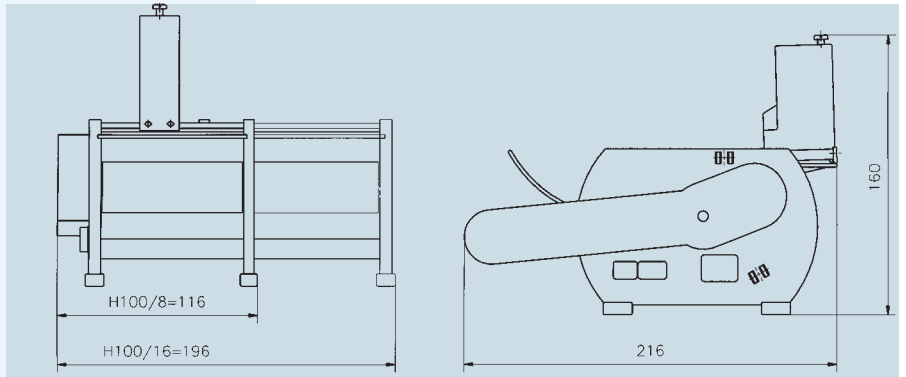

Dimensions of the HERMA 100

Technical specifications HERMA 100 dispenser

Reel width	_____	max. 80 or 160 mm
Diameter label reel	_____	max. 130 mm
Diameter reel core	_____	any
Label winding	_____	inside
Power supply	_____	230 V / 50Hz
Power consumption	_____	30 W
Dimensions HERMA 100/8 (LxWxH, approx.)	_____	216x116x160 mm
Dimensions HERMA 100/16 (LxWxH, approx.)	_____	216x196x160 mm

HERMA pursue a policy of continuous product improvement and as such we reserve the right to modify the designs and specifications of our equipment as required.



DIN EN ISO 14001



DIN EN ISO 9001:2000



HERMA
Labelling Systems

HERMA GmbH
Division Labelling Systems
Ulmer Straße 300
D-70327 Stuttgart, Germany
Telephone +49 (0)7 11 77 02-449
Fax +49 (0)7 11 77 02-428
mail@herma.de
www.herma.com